

Overview

The rechargeable batteries are lead-lead dioxide systems. The dilute sulfuric acid electrolyte is absorbed by separators and plates and thus immobilized. Should the battery be accidentally overcharged producing hydrogen and oxygen, special oneway valves allow the gases to escape thus avoiding excessive pressure build-up. Otherwise, the battery is completely sealed and is, therefore, maintenance-free, leak proof and usable in any position.



Battery Construction

Component	Positive plate	Negative plate	Container	Cover	Safety valve	Terminal	Separator	Electrolyte
Raw material	Lead dioxide	Lead	ABS	ABS	Rubber	Copper	Fiberglass	Sulfuric acid

General Features

- Positive and negative plates in lead-calcium-tin alloy;
- Stable Quality&High Reliability;
- Sealed Construction;
- Long Service Life;
- Maintenance-Free Operation;
- Low Pressure Venting System;
- Low Self Discharge;
- U.L.Component Recognition;
- Six months shelf life at 20°C;
- Design life 10 years

Battery Specification

Performance Characteristics	
Nominal Voltage	12V
Number of cell	6
Design Life	10 years
Nominal Capacity 77°F(25°C)	
20 hour rate (11.5A, 10.5V)	230Ah
10 hour rate (22.0A, 10.8V)	220Ah
1 hour rate (150A, 9.6V)	150Ah
Internal Resistance	
Fully Charged battery 77°F(25°C)	≤2.8 mOhms
Self-Discharge	
3% of capacity declined per month at 20°C(average)	
Operating Temperature Range	
Discharge	-20~60°C
Charge	-10~60°C
Storage	-20~60°C
Max. Discharge Current 77°F(25°C)	1100A(5s)
Short Circuit Current	4300A
Charge Methods: Constant Voltage Charge 77°F(25°C)	
Cycle use	2.30-2.35VPC
Maximum charging current	69.0A
Temperature compensation	-30mV/°C
Standby use	2.23-2.27VPC
Temperature compensation	-20mV/°C

Dimensions and Weight

Length(mm / inch)	520 / 20.5
Width(mm / inch)	269 / 10.6
Height(mm / inch)	203 / 8.0
Total Height(mm / inch)	208 / 8.2
Approx. Weight(Kg / lbs)	72.6 / 160.1

* Weight deviation: ± 3%

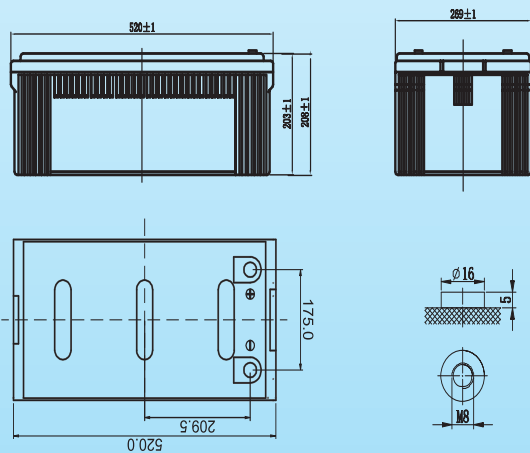

Discharge Constant Current (Amperes at 77°F25°C)

End Point										
Volts/Cell	10min	15min	30min	45min	1h	3h	5h	10h	20h	
1.60V	--	362	230	174	150	66.5	43.4	22.4	11.7	
1.65V	--	358	228	172	149	65.2	43.1	22.3	11.7	
1.70V	--	350	226	170	148	64.8	42.9	22.2	11.6	
1.75V	--	342	224	168	147	63.8	42.6	22.1	11.5	
1.80V	--	336	222	166	146	63.5	42.3	22.0	11.4	

Discharge Constant Power (Watts at 77°F25°C)

End Point								
Volts/Cell	10min	15min	30min	45min	1h	2h	3h	5h
1.60V	--	650	458	356	290	168	128	84.7
1.65V	--	645	453	353	286	165	126	84.4
1.70V	--	636	449	350	280	161	124	84.1
1.75V	--	628	445	348	275	158	122	83.8
1.80V	--	620	442	345	270	155	120	83.4

(Note)The above characteristics data are average values obtained within three charge/discharge cycles not the minimum values.All data shall be changed without notice, Vision reserves the right to explain and update the information contained hereinto.

