



For motorhomes, caravans and boats with highest energy demands.

The new Professional Li-Ion battery is designed to power electrical equipment for a home-like living experience. It's improved Depth of Discharge (DoD) delivers even more usable energy and consistent performance. The fast recharge allows it to be back to 100% within 2-3 hours. At the same time, the significantly reduced weight and size make it easy to handle and install. Inbuilt cell heating function and the high protection class guarantee that the Professional Li-Ion battery operates effectively and reliably even under demanding conditions. The special App ensures you stay informed via bluetooth on battery state of charge, overall health, cycles & usage, internal temperature, current and alarms for all BMS functions. VARTA batteries deliver precision performance and lasting reliability.

VEHICLE KEY BENEFITS



20x cycle life

20x cycle life compared with a conventional lead acid battery.



Lightweight

Twice the usable energy with 55%* weight saving compared to advanced conventional lead acid batteries (*H8/L5 with 100 Ah).



Smart connect

Smart connection options such as Bluetooth or CAN bus.



Serial and parallel connection

Capable for series and parallel connection.



Heating function

Low temperature variants with cell heating function.



Protection class IP67 (50Ah - IP54)

VARTA batteries come with high water and dust ingress protection ratings, ensuring durability and reliability even in harsh environments.



Designed in Germany

Precision design for outstanding performance and customer experience.



Maintenance-free

Maintenance-free battery designed to deliver dependable performance for your vehicle.

PROFESSIONAL LI-ION

850150001K31A

TECHNICAL DATA

Capacity:	150 Ah	CCA:	-
Voltage:	12,8 V	Dimensions (L/W/H):	353/175/190
Case Size:	H8/L5	Short Code:	LL150LT
UK-Code:	019LIO	ETN:	850150001
Weight filled:	17 kg	Base Hold-down:	B13
Layout:	0	Terminal Type:	1

DRAWINGS

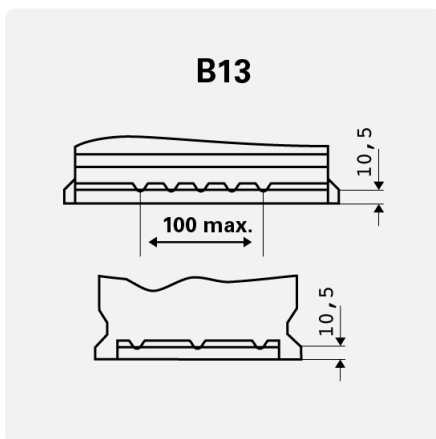

Base Hold-down

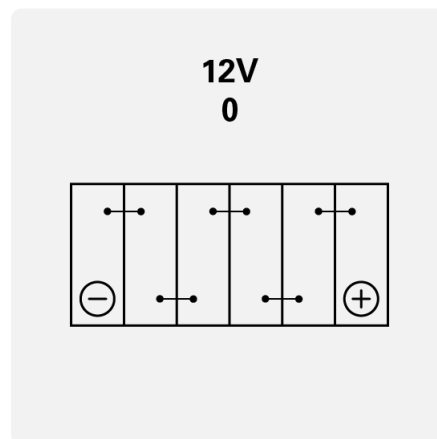

Layout

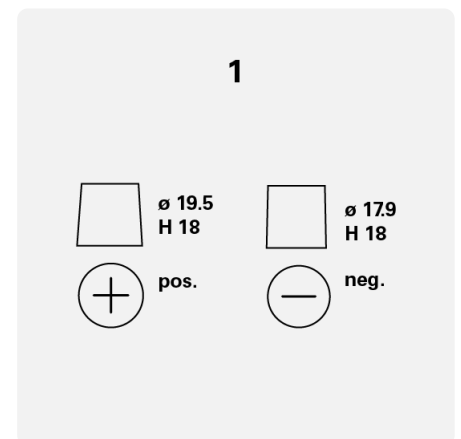

Terminal Type